

SIDE VIEW

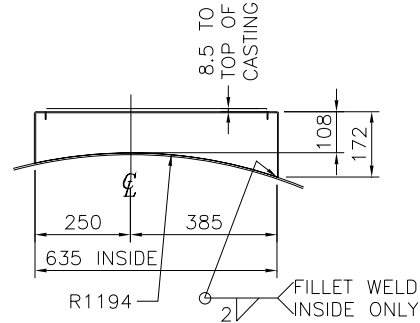

VIEW ON REAR END

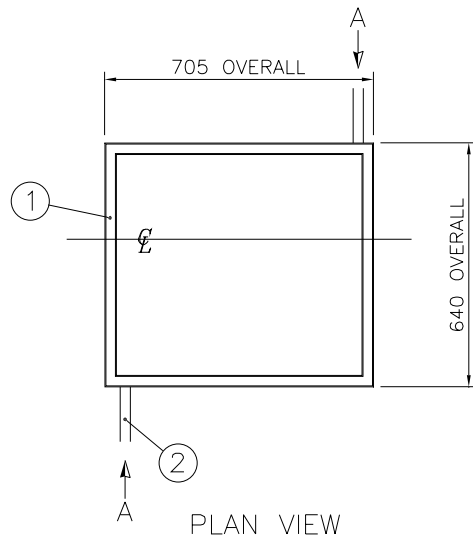

PLAN VIEW

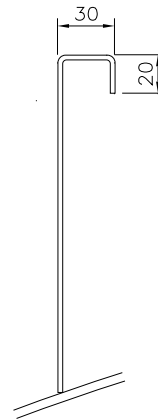

PROFILE DETAIL

MATERIAL SPECIFICATION

E	ASTM A240 304					
PARTS LIST						
No.	QTY	MAT	STOCK CODE	DESCRIPTION	DIMENSIONS	REFERENCE
1	1	E	-	SPILLBOX NECK	PLATE 2.5x212x1335	(2-OFF)
2				DRAIN TUBES		SEE DRAWING LIST
3				SPILLBOX LID	(IF APPLICABLE)	SEE DRAWING LIST

NOTE:

- SPILLBOX TO BE PICKLED AND PASSIVATED BEFORE WELDING TO SHELL.
- QUANTITIES GIVEN ARE FOR 1-OFF T.C. \_\_\_-OFF TANK CONTAINERS IN CONTRACT

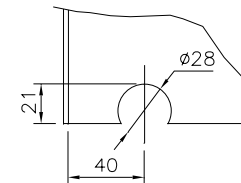

VIEW ON A

	<b>CONSANI ENGINEERING (PTY) LTD</b> ELSIES RIVER, CAPE SOUTH AFRICA TEL. 590-3400 FAX. 591-2825	
	<b>INTERMODAL CONTAINERS</b>	
THIS DRAWING AND INFORMATION IS THE PROPERTY OF CONSANI ENG. (PTY) LTD AND MAY NOT BE REVEALED TO ANY THIRD PARTY WITHOUT OUR WRITTEN PERMISSION.		CAD: HO3U2399g

REVISION B				REVISION A				DRAWING APPROVAL			NOMINAL DIMENSIONS (SHORT SIDE OF TRIANGLE)														
AUTHORITY	SIGN.	DATE	DESCRIPTION	AUTHORITY	SIGN.	DATE	DESCRIPTION	AUTHORITY	SIGNATURE	DATE	REQUIRED TOLERANCE	DEGREES & MINUTES			MM/M										
												ABOVE 0 TO 315	ABOVE 315 TO 1000	ABOVE 1000	ABOVE 0 TO 315	ABOVE 315 TO 1000	ABOVE 1000	ABOVE 0 TO 120	ABOVE 120 TO 315	ABOVE 315 TO 1000	ABOVE 1000 TO 2000	ABOVE 2000 TO 4000	ABOVE 4000 TO 8000		
DRAWN				DRAWN	R.R	19/6/01	REFERENCE CHANGE TO SEE DRAWING LIST	DESIGN	S.E.	25/4/00	A	± 20'	± 15'	± 10'	± 6	± 4.5	± 3	± 1	± 1	± 2	± 3	± 4	± 4	± 6	
DESIGN				DESIGN	E.M	19/6/01		QUALITY ASSURANCE				B	± 45'	± 30'	± 20'	± 13	± 9	± 6	± 2	± 2	± 3	± 4	± 6	± 8	± 10
QUALITY ASSURANCE				QUALITY ASSURANCE				CONTRACTS	A.L.	25/4/00		C	± 1'	± 45'	± 30'	± 18	± 13	± 9	± 3	± 4	± 6	± 8	± 11	± 14	± 18
CONTRACTS				CONTRACTS	A.L	19/6/01		INSPECTION AUTHORITY				D	± 1'30'	± 1'15'	± 1'	± 26	± 22	± 18	± 4	± 7	± 9	± 12	± 16	± 21	± 27
INSPECTION AUTHORITY				INSPECTION AUTHORITY				CLIENT				DIN 8570 PART 1						FROM 0-30 TOLERANCE ±1 DIN 8570 PART 3							

TOP DISCHARGE SPILLBOX DETAIL  
MODEL HO3 - 25 000 LITRE

CLIENT		SCALE	1:10	DRAWING NUMBER		REVISION	
WORKS ORDER		DRAWN	G.Purdon	HO3U 2399	A		
		CHECKED					
		DATE	18/4/2000				