

MATERIAL SPECIFICATION

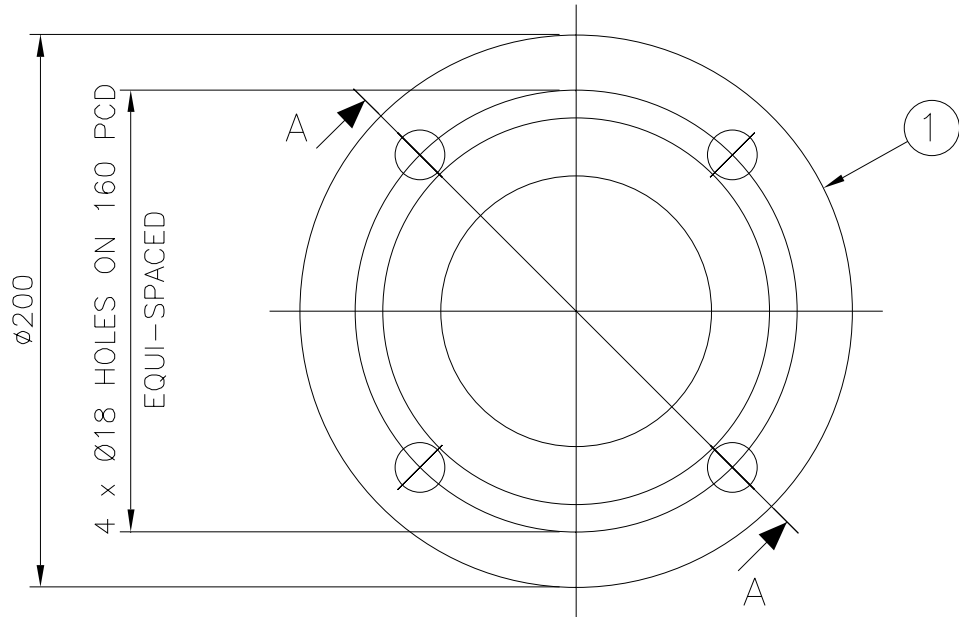

C	ASTM A240 316 OR 316L		



N8
ALL OVER
U.O.S.

NOTE:

FLANGES TOLERANCED TO ANSI B16.5 U.O.S.
REMOVE ALL SHARP EDGES AND BURRS
PICKLE & PASSIVATE FLANGE

DO NOT SCALE DRAWING

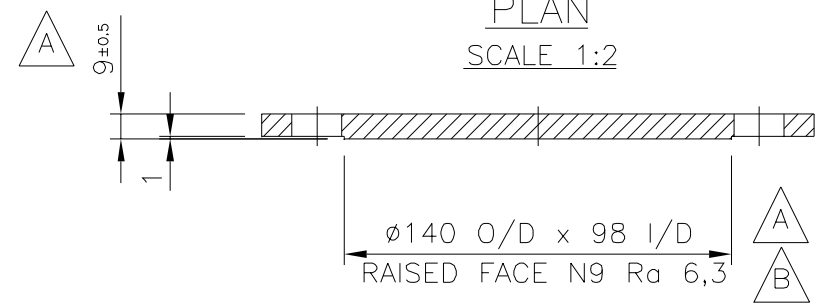

SECTION A-A
SCALE 1:2

1	1	C	8046	FLANGE Ex PL10 x 200 O/D	
ITM	QTY	MAT	BOP Pg/No	DESCRIPTION	REF

PARTS LIST

CONSANI ENGINEERING (PTY) LTD
 ELSIES RIVER, CAPE TEL. 590-3400
 SOUTH AFRICA FAX. 591-2825

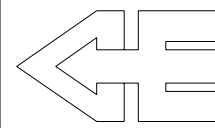

INTERMODAL CONTAINERS
THIS DRAWING AND INFORMATION IS THE PROPERTY OF CONSANI ENG (PTY) LTD AND MAY NOT BE REVEALED TO ANY THIRD PARTY WITHOUT OUR WRITTEN PERMISSION.
 CAD:

3" (80 NB)
TOP DISCHARGE BLIND FLANGE

REVISION B				DRAWING APPROVAL		
AUTHORITY	SIGN.	DATE	DESCRIPTION	AUTHORITY	SIGNATURE	DATE
DRAWN	S.N.	28/01	MACHINING DETAILS ON SERRATIONS & FINISHING REVISED MATERIAL SPEC. REVISED	DESIGN	S.E.	25/3/94
DESIGN	E.M	10/03/97		QUALITY ASSURANCE	P.B.	7/4/94
QUALITY ASSURANCE				CONTRACTS	M.H.	7/4/94
CONTRACTS	A.C	10/03/97		INSPECTION AUTHORITY		
INSPECTION AUTHORITY				CLIENT		

CLIENT	SCALE 1:2	DRAWING No.	REV
	DRAWN K.E.		
W.O.	CHECKED	CSTD 4	B
	DATE 28/02/96		