

PLAN SCALE 1:2

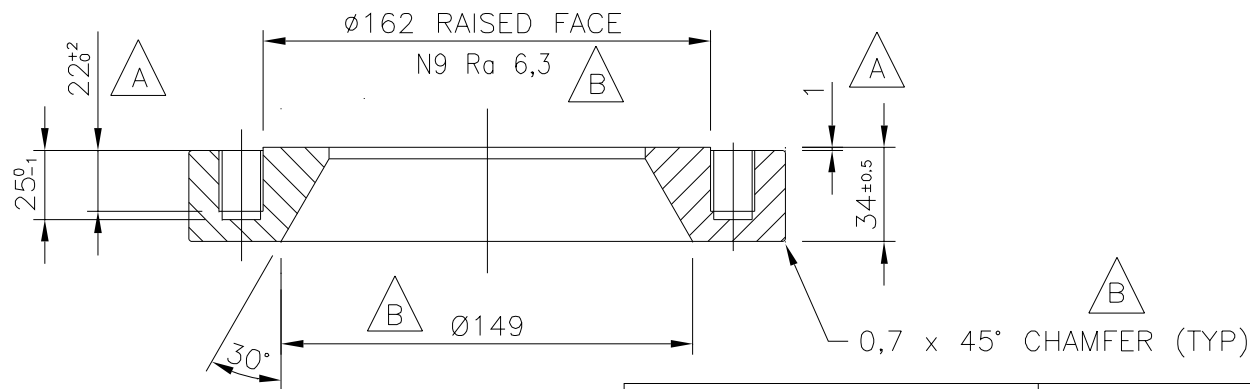

SECTION A-A
SCALE 1:2

REVISION B				DRAWING APPROVAL		
AUTHORITY	SIGN.	DATE	DESCRIPTION	AUTHORITY	SIGNATURE	DATE
DRAWN	S.N.	27/11	MACHINING DETAILS ON SERRATIONS & FINISHING REVISED	DESIGN	S.E.	25/3/96
DESIGN	E.M	10/03/97		QUALITY ASSURANCE	P.B.	7/4/96
QUALITY ASSURANCE				CONTRACTS	M.H.	7/4/96
CONTRACTS	A.C	10/03/97		INSPECTION AUTHORITY		
INSPECTION AUTHORITY				CLIENT		

MATERIAL SPECIFICATION



C	ASTM A240 316 OR 316L		
---	-----------------------	--	--

N8
ALL OVER
U.O.S.

NOTE:

FLANGES TOLERANCED TO ANSI B16.5 U.O.S.
REMOVE ALL SHARP EDGES AND BURRS
PICKLE & PASSIVATE FLANGE

DO NOT SCALE DRAWING

1	1	C	8048	FLANGE Ex PL35 x 114 I/D x 216 O/D	
ITM	QTY	MAT	BOP Pg/No	DESCRIPTION	REF

PARTS LIST

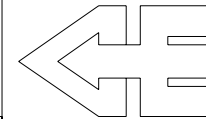

CONSANI ENGINEERING (PTY) LTD
ELSIES RIVER, CAPE TEL. 590-3400
SOUTH AFRICA FAX. 591-2825

INTERMODAL CONTAINERS

THIS DRAWING AND INFORMATION
IS THE PROPERTY OF CONSANI
ENG (PTY) LTD AND MAY NOT
BE REVEALED TO ANY THIRD
PARTY WITHOUT OUR WRITTEN
PERMISSION.

CAD: CSTD0012

30° BOTTOM DISCHARGE WELD PAD

CLIENT	SCALE 1:2	DRAWING No.	REV
	DRAWN K.E.		
W.O.	CHECKED	CSTD 12	B
	DATE 28/02/96		