

MATERIAL SPECIFICATION			
W	DIN17440 W1.4406	N	DIN17441 W1.4401
	C<=0.03% (1985 EDITION)		C<=0.03% (1985 EDITION)

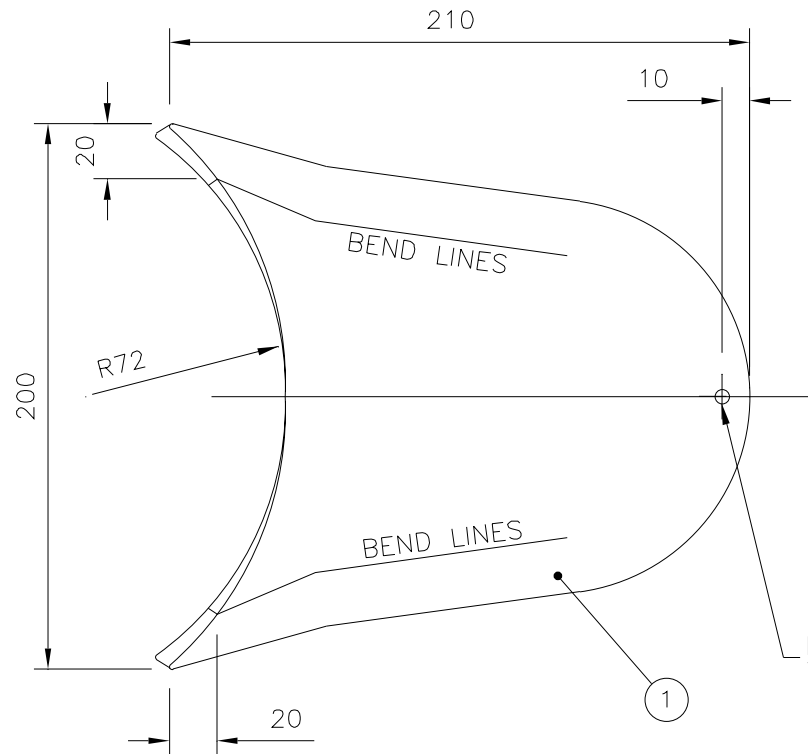

CLEANING PROCESS:
 POLISH INTERNAL SURFACE -
 R_a 1.3 MICRONS (180 GRIT) &
 REMOVE BURRS & SHARP EDGES



TOP VIEW

DRILL ϕ 5.2 HOLE &
 TAP TO M6

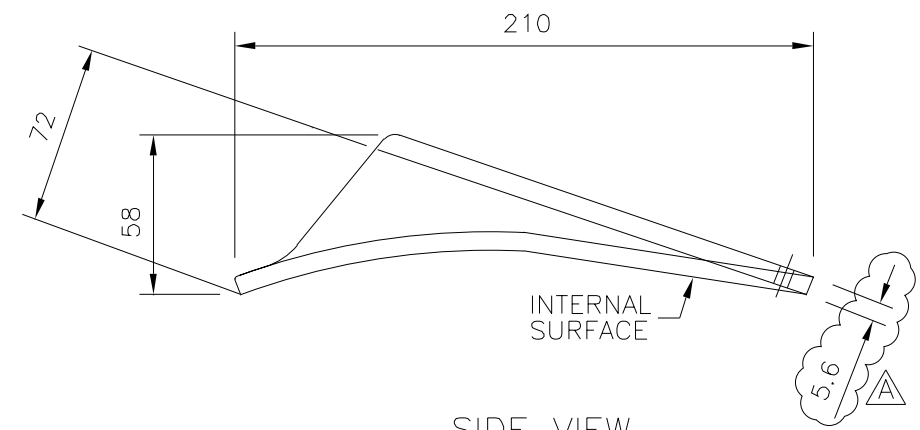

SIDE VIEW

No	QTY	MAT	STOCK CODE	DESCRIPTION	REFERENCE
1	1	W/N	14000	BOTTOM DISCHARGE FILLER PLATE	

PARTS LIST

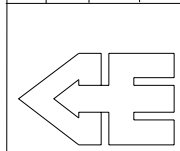

CONSANI ENGINEERING (PTY) LTD

ELSIES RIVER, CAPE SOUTH AFRICA
 TEL. 590-3400 FAX. 591-2825

INTERMODAL CONTAINERS

THIS DRAWING AND INFORMATION IS THE PROPERTY OF CONSANI'S ENG. (PTY) LTD AND MAY NOT BE REVEALED TO ANY THIRD PARTY WITHOUT OUR WRITTEN PERMISSION.

CAD FILENAME:
 BDF 00

BOTTOM DISCHARGE FILLER PLATE

REVISION A				DRAWING APPROVAL		
AUTHORITY	SIGN.	DATE	DESCRIPTION	AUTHORITY	SIGNATURE	DATE
DRAWN	T.J.B.	06/2/01	THICKNESS REVISED	DESIGN	E.M.	13/9/99
DESIGN	E.M.	06/2/01	MATERIAL N ADDED.	CONTRACTS	A.C.	13/9/99
CONTRACTS	A.L.	06/2/01				

CLIENT.	SCALE	NTS	DRAWING No.	REV.
W.O.			BDF 00	A
	DRAWN	Y.GOOSEN		
	CHECKED			
	DATE	10/09/99		