

SIDE VIEW

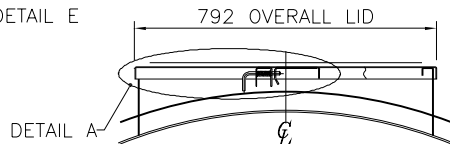

VIEW ON REAR END

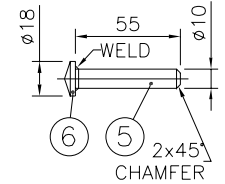

PIVOT PIN DETAIL

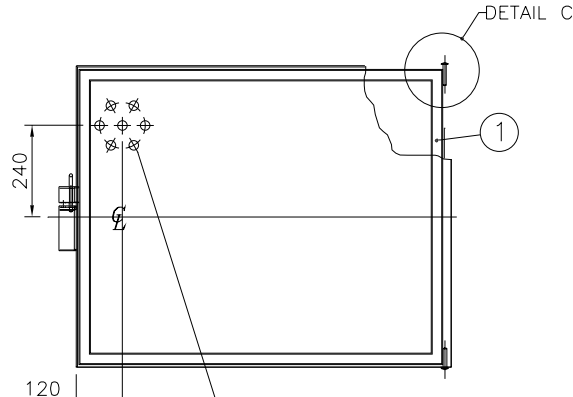

DRILL A GROUP OF $\phi 25$ HOLES.
1 HOLE AT CENTRE, 6 HOLES
EQUI-SPACED ON 120 P.C.D.

PLAN VIEW

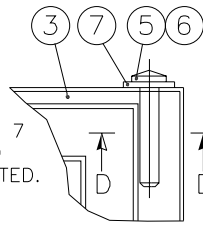

DETAIL C

WELD WASHER ITEM 7
IN PLACE ONCE LID
IS POSITIVELY LOCATED.

WELD BOTTOM OF PIVOT PIN
WHEN LID IS CLOSED, WELD
ON TOP WHEN LID IS OPEN.
WELD FULL LENGTH ON TOP
AND BOTTOM.

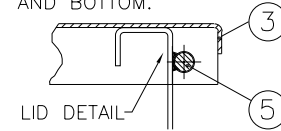

SECTION D-D

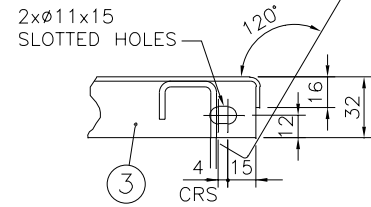

DETAIL E

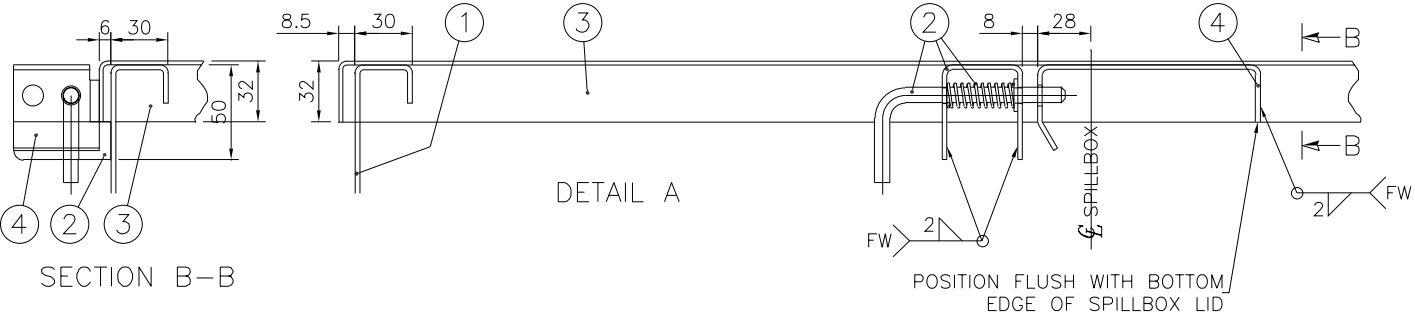

SECTION B-B

DETAIL A

POSITION FLUSH WITH BOTTOM
EDGE OF SPILLBOX LID

MATERIAL SPECIFICATION						
E	ASTM A240 304	Z	S/S 304			
PARTS LIST						
No.	QTY	MAT	STOCK CODE	DESCRIPTION	DIMENSIONS	REFERENCE
1				MANWAY SPILLBOX		SEE DRG.LIST
2			8099	LOCKING PIN		
3	1	E	-	SPILLBOX LID	PLATE 2x848x1025	
4	1	E	-	HANDLE	PLATE 2.5x45x175	
5	2	Z	-	PIVOT PIN	$\phi 10 \times 55$ LONG	
6	2	Z	-	PIVOT PIN RETAINER	$\phi 18 \times 3$ THK	
7	2	Z	-	FLAT WASHER	M10	

NOTE:

- QUANTITIES GIVEN ARE FOR 1-OFF T.C.
50-OFF TANK CONTAINERS IN CONTRACT

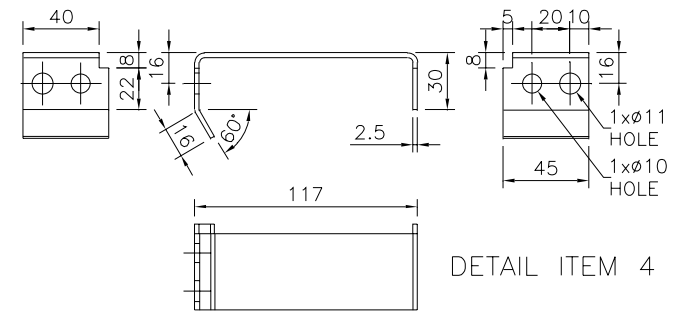

DETAIL ITEM 4

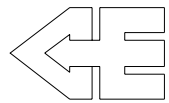
	CONSANI ENGINEERING (PTY) LTD ELSIES RIVER, CAPE SOUTH AFRICA		TEL. 590-3400 FAX. 591-2825	
	INTERMODAL CONTAINERS			<small>THIS DRAWING AND INFORMATION IS THE PROPERTY OF CONSANI ENG. (PTY) LTD AND MAY NOT BE REVEALED TO ANY THIRD PARTY WITHOUT OUR WRITTEN PERMISSION.</small> CAD: 24422041

REVISION B				REVISION A				DRAWING APPROVAL			NOMINAL DIMENSIONS (SHORT SIDE OF TRIANGLE)													
AUTHORITY	SIGN.	DATE	DESCRIPTION	AUTHORITY	SIGN.	DATE	DESCRIPTION	AUTHORITY	SIGNATURE	DATE	REQUIRED TOLERANCE	DEGREES & MINUTES				MM/M								
												ABOVE 0 TO 315	ABOVE 315 TO 1000	ABOVE 1000 TO 315	ABOVE 315 TO 1000	ABOVE 0 TO 120	ABOVE 120 TO 315	ABOVE 315 TO 1000	ABOVE 1000 TO 2000	ABOVE 2000 TO 4000	ABOVE 4000 TO 8000			
DRAWN				DRAWN				DESIGN			A	$\pm 20'$	$\pm 15'$	$\pm 10'$	$\pm 6'$	$\pm 4.5'$	$\pm 3'$	$\pm 1'$	$\pm 2'$	$\pm 3'$	$\pm 4'$	$\pm 4'$	$\pm 6'$	
DESIGN				DESIGN				QUALITY ASSURANCE			B	$\pm 45'$	$\pm 30'$	$\pm 20'$	$\pm 13'$	$\pm 9'$	$\pm 6'$	$\pm 2'$	$\pm 2'$	$\pm 3'$	$\pm 4'$	$\pm 6'$	$\pm 8'$	$\pm 10'$
QUALITY ASSURANCE				QUALITY ASSURANCE				CONTRACTS			C	$\pm 1'$	$\pm 45'$	$\pm 30'$	$\pm 18'$	$\pm 13'$	$\pm 9'$	$\pm 3'$	$\pm 4'$	$\pm 6'$	$\pm 8'$	$\pm 11'$	$\pm 14'$	$\pm 18'$
CONTRACTS				CONTRACTS				INSPECTION AUTHORITY			D	$\pm 1'30'$	$\pm 1'15'$	$\pm 1'$	$\pm 26'$	$\pm 22'$	$\pm 18'$	$\pm 4'$	$\pm 7'$	$\pm 9'$	$\pm 12'$	$\pm 16'$	$\pm 21'$	$\pm 27'$
INSPECTION AUTHORITY				INSPECTION AUTHORITY				CLIENT			DIN 8570 PART 1				FROM 0-30 TOLERANCE ± 1				DIN 8570 PART 3					

MANWAY SPILLBOX LID DETAIL

CLIENT	OCI	SCALE	1:10	DRAWING NUMBER		REVISION	
WORKS ORDER	2442	DRAWN	RASHAAD	DRAWING NUMBER	2442-02-2041	REVISION	0
		CHECKED		DATE	13/02/02		